

EVAC-105 / EVDC-105 ENERGY STORAGE

EVERVOLT™ HOME ENERGY STORAGE SYSTEM

Optimize your solar investment and create a more resilient energy future. With EverVolt you can store your excess solar power for when you need it most or sell your surplus energy back to your local utility.

FEATURES

- Modular design with storage options from 11-102kWh to fit your needs*
- User friendly app to easily see your system’s performance
- Multiple operating modes
- Three main components for simple installation
- 10-year Panasonic warranty

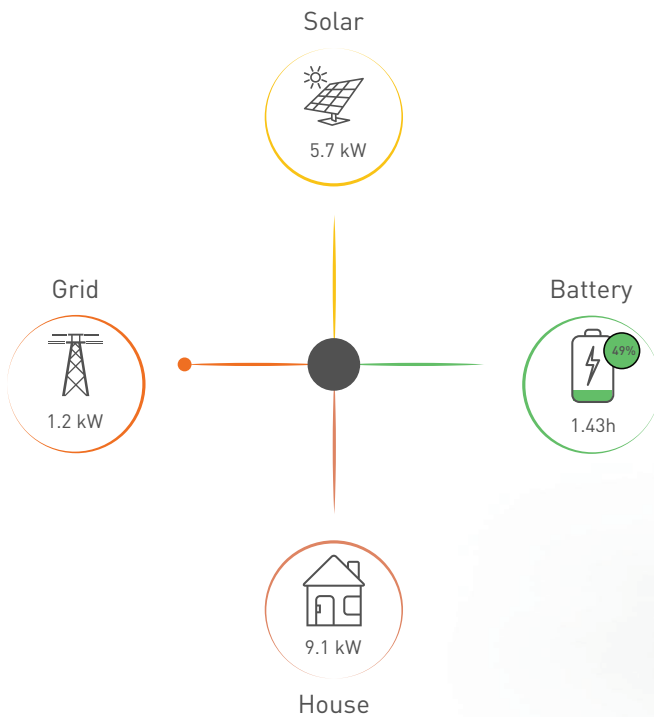

AC coupled version shown above. DC coupled system available in black only.

*Up to 34 kWh achievable using two battery enclosures. Up to 102 kWh achievable with DC coupled system.

EVAC-105 / EVDC-105 ENERGY STORAGE

MODEL INFORMATION

Size	Standard	Plus
AC Coupled Model #	EVAC-105-4	EVAC-105-6
DC Coupled Model #	EVDC-105-4	EVDC-105-6
Usable Energy ¹	11.4 kWh	17.1 kWh
Continuous Output Power to Loads	4.6 kW	5.5 kW
Maximum Output Power to Grid	5.0 kW	5.0 kW
Average Backup Capability ²	6 hours	9 hours

¹measured at battery cell level

ELECTRICAL SPECIFICATIONS

	Off-Grid/Backup	With Grid Support (self-supply/TOU)
Inverter Maximum Output Power to Grid	--	5.0 kW
Inverter Continuous Output Power to Loads ²	5.5 kW	7.0 kW
Inverter Peak Output Power to Loads [40s / 30s / 5s / 1s]	5.5/--/6.5/7.5 kW	--/7.5/--/-- kW
Rated Continuous Output Current (RMS)	23A @120V / 240V	29A @120V / 240V
Nominal AC Voltage	120V / 240V	
Grid Frequency (auto sensing)	50Hz / 60Hz	
Operating Voltage Range (DC Coupled Only)	120 - 500 VDC	
MPPT Voltage Range (DC Coupled Only)	250 - 430 VDC	
Maximum PV Array Input (DC Coupled Only)	6.5 kW DC	
Nominal DC Battery Voltage	46.2V	
Roundtrip Efficiency (AC Coupled / DC Coupled)	86% / 90%	

²Up to 21 kW continuous power available to loads with grid support when stacking systems.

MECHANICAL SPECIFICATIONS

Inverter Dimensions (HxWxD)	AC Coupled	33.7 x 18.0 x 6.0 in [856 x 455 x 150 mm]
	DC Coupled	39 x 17.6 x 5.9 in [990 x 448 x 150 mm]
Battery Cabinet Dimensions (HxWxD)	24.2 x 65.5 x 10 in. [615 x 1664 x 245 mm]	
Inverter Weight	AC Coupled	74.0 lbs [33.6 kg]
	DC Coupled	86.8 lbs [39.4 kg]
Battery Cabinet Weight	106 lbs [48.1 kg]	
Battery Module Weight (each)	55 lbs [25 kg]	
Protection Rating	NEMA 1 Indoor	
Mounting	Floor/Wall	
Operating Temperature (charge)	41°F to 131°F [5°C to 55°C]	
Operating Temperature (discharge)	32°F to 122°F [0°C to 50°C]	
Storage Temperature	-13°F to 158°F [-25°C to 70°C]	
Max Altitude	9843 ft. [3000 m]	
Noise Level	< 63 dB	

GENERAL SPECIFICATIONS

	Standard	Plus
Certifications	UL 1741SA, UL 1973, UL 1642, UL 9540, CSA C22.2, IEEE 1547A, IEEE 1547.1, FCC Class B	
Warranty	10 years	
Energy Throughput Warranty	30.2 MWh	45.3 MWh

DIMENSIONS

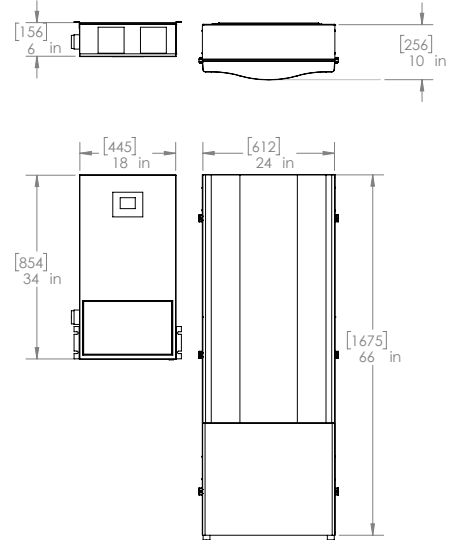

^{*}Based on average residential electricity consumption for 2017 (<https://www.eia.gov/tools/faqs/>). Consult your Panasonic Authorized Installer for a custom site analysis, as electricity consumption can vary widely based on home size, climate, and the number of energy intensive appliances such as air conditioners and EV chargers.